

C. H. BURD.  
Telegraphic-Relay Instrument.

No. 32,510.

Patented June 11, 1861.

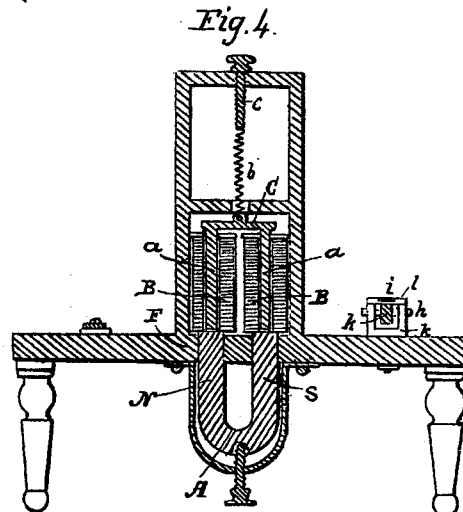
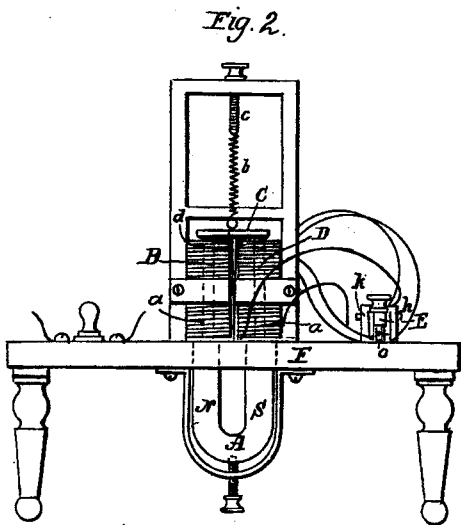
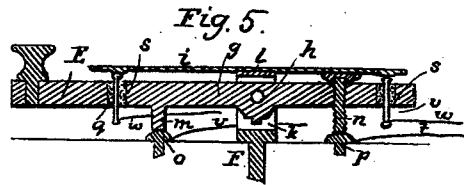
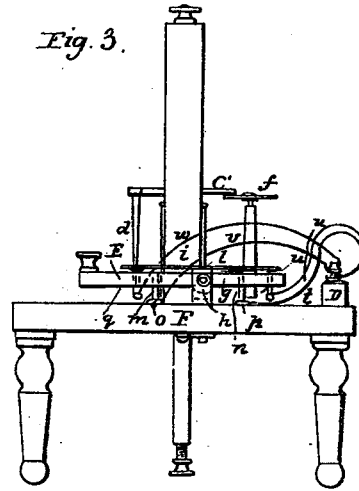
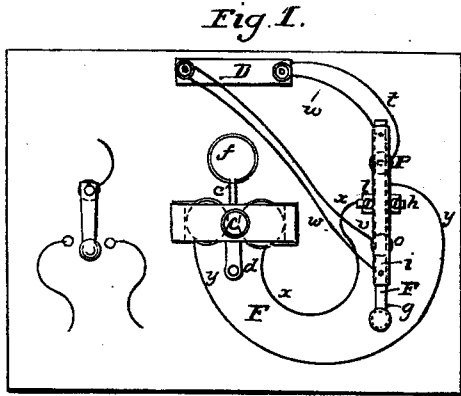

Witnesses:  
J. M. Eddy  
F. C. Nash.

Inventor:  
Chas. H. Burd.

# UNITED STATES PATENT OFFICE.

CHARLES H. BURD, OF ROXBURY, MASSACHUSETTS.

## IMPROVED TELEGRAPHIC APPARATUS.

Specification forming part of Letters Patent No. 32,510, dated June 11, 1861.

*To all whom it may concern:*

Be it known that I, CHARLES H. BURD, of Roxbury, in the county of Norfolk and State of Massachusetts, have invented a new and useful electro-magnetic apparatus to be employed for telegraphing or various other useful purposes; and I do hereby declare the same to be fully described in the following specification and represented in the accompanying drawings, of which—

Figure 1 is a top view, Fig. 2 a front elevation, Fig. 3 an end elevation, and Fig. 4 a longitudinal section, of it; Fig. 5, a longitudinal section of the key, to be hereinafter described.

In the employment of my invention in a telegraphic circuit I am enabled to dispense with local circuits and batteries, such as are essential to the Morse system of telegraphing by galvanic electricity.

Telegraphic signals may be made through a very extended circuit by my invention, in the use of which the direction of the current from the battery is to be alternately reversed—that is to say, the current, after having been sent in one direction from the battery and through the helices, is to be made to flow in the opposite direction through them.

I do not claim the invention of, nor do I employ the combination of, two helices with a permanent magnet, in such manner that each helix shall envelop one of the legs of the said permanent magnet, while the said magnet has a movable armature, such being exhibited in the patent of Alfred G. Holcomb, granted May 15, 1860.

I employ not only a permanent magnet, A, and two helices, B B, but a non-magnetic U-piece, C, of soft iron; and I not only arrange the latter so that its legs *aa* respectively may extend and play freely through the helices B B, but be opposite to the two poles N S of the permanent magnet A, as shown in the drawings. I counterbalance the soft-iron U-piece C by means either of a spring, *b*, and a screw, *c*, arranged as shown in the drawings, or by a weight. The helices are to be so arranged in or applied to the electric circuit as to make the electric current from the battery D to be thrown through them. Within the circuit I place a key, E, so made as to enable me first to send the current in one direction through the helices and next reverse the direction of

the current. By the action of the battery and such a key the U-piece C will be magnetized and will have its poles alternately reversed, the result of which will be that the U-piece will first be attracted toward and afterward repelled from the permanent magnet by the magnetisms of both. Besides the ordinary magnetism which would be generated in the U-piece C were it stationary in the helices, it will have what is termed "axial magnetism" generated in it. Therefore, for the movement of the U-piece C a great power is generated. With the U-piece I combine a mechanism for the production of either evanescent or permanent signs for telegraphing. The U-piece may be made to operate mechanism for other purposes.

The drawings exhibit the U-piece as not only having a stylus, *d*, affixed to it for marking on paper while being moved along on the top of the table F and under the point of such stylus, but is also furnished with a sounding arm or hammer, *e*, to work against a bell or an adjustable platform, *f*, either or both of which mechanical contrivances or their equivalents may be employed to effect signs by the elevations and depressions of the U-piece.

The following is a description of the key. A metallic lever, *g*, whose fulcrum is shown at *h*, has extended over it a metallic bar, which is supported by an insulating-saddle, *l*, of the support-piece *k* of the fulcrum of the said lever. A metallic stud, *m*, projects down from one arm of the lever, while from the other arm a metallic screw, *n*, also extends in a similar manner, the lower ends of the two parts *m n* having anvils or screw-heads *o p* arranged underneath them and in the top of the table F. Furthermore there are two metallic pins or bolts, *q r*, affixed in the lever on opposite sides of its fulcrum and directly under the bar *i*. Each of the said bolts *q r* is electrically insulated from the lever *g* by being passed through and fixed on a cylindrical plug, *s*, of wood or glass, inserted through the lever. Two wires, *t u*, lead respectively from the anvil *p* and the bolt *r* to one pole of the galvanic battery. (Shown at D.) Two other wires, *v w*, also lead from the anvil *o* and the bolt *q* to the other pole of the said battery. Next, the circuit-wire continues from one helix to and is joined to the bar *i*, as shown at *y*, the other end of the circuit-wire, after being extended from the other

helix, being attached to the metallic support-piece *k*, as shown at *x*. Under these circumstances, when the key is depressed the stud *m* will not only touch the anvil *o*, but the head of the bolt *r* will be brought into contact with the bar *i*, the parts *q* and *n* being at the same time thrown out of contact with the parts *p* and *i*, so when the key is elevated not only will the parts *q* and *n* be moved into contact with the parts *i* and *p*, but the parts *m* and *r* will be moved out of contact with the parts *o* and *i*. While one of these movements of the key will cause the electricity to flow into the helices in one direction, the other or reverse movement of the key will produce a counter-movement of the current.

I claim—

1. The combination of the permanent magnet *A*, the two helices *B B*, and the non-magnetic movable *U*-piece *C*, the whole being arranged substantially as explained, and so as to operate together under circumstances and in manner as specified.

2. The key as constructed and made to operate with a battery, the two helices, the permanent magnet, and the non-magnetic *U*-piece, substantially as described.

CHAS. H. BURD.

Witnesses:

R. H. EDDY,  
F. P. HALE, Jr.