

A. E. PARKS.  
Telegraphic Register.

No. 31,902.

Patented April 2, 1861.

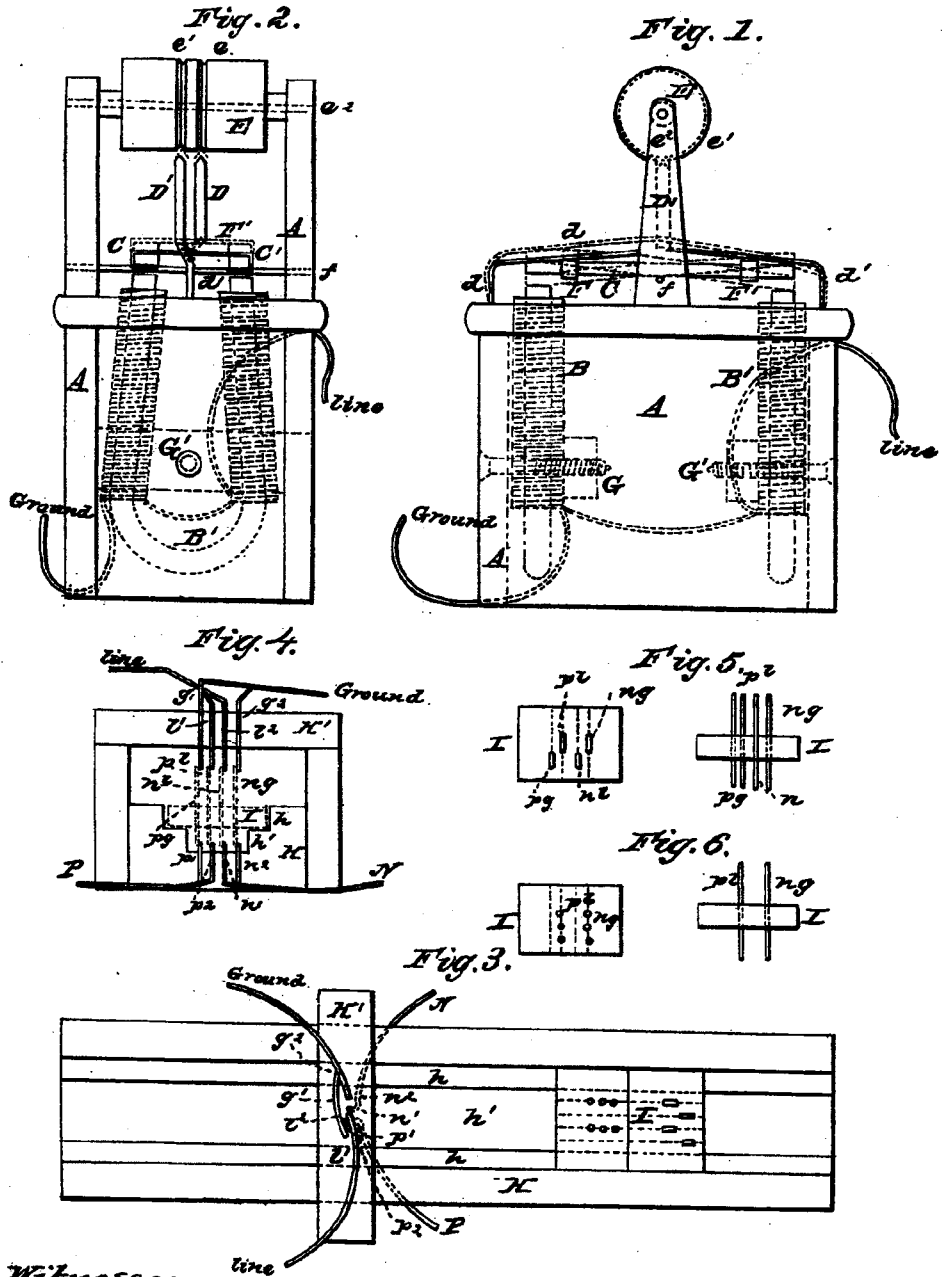

Witnesses:  
James N. Brewster  
Thomas Chatterin

Inventor:  
A. E. Parks.

# UNITED STATES PATENT OFFICE.

ALFRED E. PARKS, OF BROOKLYN, NEW YORK.

## IMPROVEMENT IN ELECTRO-MAGNETIC TELEGRAPHING.

Specification forming part of Letters Patent No. 31,902, dated April 2, 1861.

*To all whom it may concern:*

Be it known that I, ALFRED E. PARKS, of the city of Brooklyn, in the county of Kings, and State of New York, have invented a certain Improvement in Electro-Magnetic Telegraphs; and I do hereby declare that the following is a full, clear, and exact description of the same, reference being had to the accompanying drawings, which form part of this specification.

Figure 1 is a side view of the receiving apparatus or register. Fig. 2 is an end view of the same. Fig. 3 is a top view of the port-rule or type-guide, showing two types placed therein. Fig. 4 is an end view of the same, having the types shown in colors. Fig. 5 is a top and front view of the type necessary to form the letter P in my alphabet. Fig. 6 is a top and front view of the type similarly necessary to form the letter B.

Similar letters of reference indicate corresponding parts in all the figures in which they occur.

My invention consists, first, in the recording of a telegraphic alphabet by means of two pencils, one of them being operated by positive and one by negative electricity.

My invention consists, secondly, in a new telegraphic alphabet composed of dots and dashes written in either of two positions on the paper.

My invention consists, thirdly, in a new description of type by which letters or signals constructed as above described may be transmitted with great rapidity.

To enable others skilled in the art of telegraphy to fully understand and construct my invention, I will proceed to describe it.

A represents a framing, which may be constructed in any manner thought proper to support the working parts.

B B' represent two electro-magnets, so placed and connected that their similar poles shall always be opposite each other.

C C' represent two permanent magnets, hung upon an axis, *f*, and having their dissimilar poles opposed to each other.

D D' represent two styles or pencils, placed side by side, and mounted, respectively, on the springs *d d'*, which have one end fastened into the frame A.

E represents a roller, revolving on the axis *e<sup>2</sup>*, and having two grooves, *e e'*, cut round its face, in such a position as that they shall respectively receive the points of D D'.

F F' represent two brass ties, which serve both to maintain a proper distance between C and C' and to communicate motion to *d* D and *d'* D' respectively.

G G' represent two screws and nuts, which serve to brace B B' in place.

H represents the port-rule or type guide, which is placed at the transmitting-station. It is constructed with a groove, *h*, in which the type slide, and a lower groove, *h'*, in which are fixed the projecting ends of four wires, *p'*, *p<sup>2</sup>*, *n'*, and *n<sup>2</sup>* *p'* and *p<sup>2</sup>* being united into P, and connected with the positive pole of the battery, and *n'* and *n<sup>2</sup>* similarly united into N, and connected with the negative pole. An arch or bridge, H', is also fixed to it, which holds the ends of the four wires *g'*, *l'*, *l<sup>2</sup>*, and *g<sup>2</sup>*, placed directly above *p'*, *p<sup>2</sup>*, *n'*, and *n<sup>2</sup>*, *g'* and *g<sup>2</sup>* being united and connected with the ground, and *l'* and *l<sup>2</sup>* similarly connected with the line. These eight wires are insulated from each other, except where any two of them are united, as above described. This port-rule may be made of indefinite length, and type already set up may be placed in it and propelled along it by any suitable mechanical means.

I represents the body of my type, formed of some suitable non-conductor, and of just such size as to slide easily in the groove *h*. It is furnished with brass or copper wires and flat pieces *p<sup>2</sup>* *p'* *n<sup>2</sup>* *n'*, their number, size, and position varying with the character intended to be transmitted through them. If these conducting-pieces are themselves properly insulated, I may be, if considered convenient, made of conducting materials. To transmit a dash a pair of flat pieces of metal are used in the type, so that the circuit may continue closed for an appreciable time through them while the type is in motion. To transmit a dot two simple pieces of wire are used. These conducting-pieces are of such a length and fixed in such a position laterally that they will form a good binding-contact each with one of the wires in the groove *h'* at the same time with one of those in the bridge H'.

There is no permanent connection with either the ground or the line.

The operation is as follows: The message or series of signals desired to be transmitted having been set up in type at the sending-station, is placed one line at a time in the port-rule or type-guide, H, and propelled rapidly under the bridge H' by any suitable mechanical means. Let the first type which reaches the bridge H'

be the one intended to transmit the letter B, and consisting of three pairs of wires. When the first pair of wires reaches the eight wires set in the groove *b'* and bridge H', a positive current is thrown on the line-wire from *p*<sup>2</sup> through *p'* to *l'*, and a negative connection established with the ground from *g*<sup>2</sup> through *n*<sup>2</sup> to *n'*, as shown by the red lines in Fig. 4. The circuit being thus closed, a positive current is received at the receiving-station which excites B B'; but these being arranged so that their similar poles shall always be opposed, while C' C have their dissimilar poles in opposition, it follows that if the poles of B' are similar to those immediately over them of C C', then those of B must be dissimilar to those of C C' immediately over them. Now, in the mutual action of magnets, similar poles repel each other and opposite poles mutually attract; therefore, B' repels the two poles of C C' above it, and B attracts their two poles which are above its own. This joint and simultaneous action of both the attractive and repulsive forces, acting through the tie F, overcomes the resistance of the spring *d'*, the stylus D' is raised, as shown by the red lines in Fig. 1, and a mark made on the paper in the groove *e'*. The circuit is now broken by the passing of *p'* and *n*<sup>2</sup> beyond the wires *p*<sup>2</sup>, *l'*, *n'*, and *g*<sup>2</sup> at the sending-station; therefore B and B' become inert, *d'* restores C and C' to their normal position and brings D' down, a dot having been made. The paper is moved forward between D and E by the machinery now used for that purpose or any other which may be found suitable. The same effects follow upon the other contacts of the wires in this type.

Supposing that the next type is intended to transmit the signals representing P, the circuit is closed in the same manner, and the same effects follow upon the contacts of the first pair of conducting-pieces, *p'* and *n*<sup>2</sup>, except that these pieces, being flat strips of metal, not wires, keep the circuit closed long enough to mark a dash on the moving paper at the receiving-station; but when the next pair of conducting-pieces, *p*<sup>2</sup> and *n'*, make their contacts the whole current is reversed. A positive current is transmitted to the ground through *p'*, *p*<sup>2</sup>, *g'* and a negative connection made with the line-wire through *l'*, *n'*, *n'*, as shown by the blue lines in Fig. 4. B B' are again excited, but in consequence of the reversal of the exciting current their polarities are reversed, they having north poles where south polarity was previously manifested and south poles in the place of north ones, C C' remaining unchanged. In consequence of this change, those ends of C C' which were previously repelled are attracted, and those which were attracted are repelled—that is to say, B repels the two poles of the permanent magnets which are directly above its own and B' attracts its two adjoining poles. The tie F is raised, which in turn strains *d* and raises D, as shown by the blue lines in Fig. 1, holding it up so long as the circuit shall remain closed. But as D and D' are placed sidewise

to each other, they cannot each make marks in the same position on the paper, but will instead record signals in two lines, those on the one line being written by positive electricity and those on the other by negative.

Having succeeded, then, in recording signals in either of two positions on the paper, I find myself possessed of four elements out of which to construct an alphabet—namely, a dot upon the upper line, a dash upon the upper line, a dot upon the lower line, and a dash upon the lower line. From these alone and in combination I can proceed to construct an alphabet, which may be formed with fewer contacts and in less time than any telegraphic alphabet heretofore used.

The particular combination which I consider most advantageous is as follows:

A	—	J	---	S	--	2	---	,	--
B	---	K	---	T	.	3	---	;	--
C	—	L	--	U	---	4	---	.	---
D	---	M	---	V	---	5	---	?	---
E	—	N	—	W	---	6	---	!	---
F	—	O	—	X	---	7	---	'	---
G	---	P	---	Y	---	8	---	Para-	---
H	—	Q	---	Z	---	9	---	graph.	---
I	—	R	---	1	---	0	---	Italic.	---
								&	---

Any other arrangement of dots and dashes on two lines embracing long dashes or long spaces, if necessary, may be constructed.

The instrument may be used to receive by sound by interposing some soft substance, as a coat of paint or a piece of paper, between the poles of one of the electro-magnets and those of the two permanent magnets which are immediately over them.

If thought necessary, any or all of the eight wires secured in the type-guide H H' may be replaced by narrow flat pieces. This will slightly lengthen the time during which the circuit remains closed.

By the use of any suitable key—as, for instance, that used on the English needle telegraph—the alphabet herein described may be transmitted by hand.

What I claim as my invention, and desire to secure by Letters Patent, is—

1. The recording of a telegraphic alphabet of dots and dashes by means of two pencils or styles, one of them being operated by positive and one by negative electricity.

2. The use of an alphabet composed, substantially as described, of dots and dashes recorded at pleasure in either of two position, on the paper.

3. The type constructed, substantially as described, of several conducting-pieces insulated from each other.

4. The use of the port-rule, constructed substantially, as described, with the wires *p'*, *p*<sup>2</sup>, *n'*, *n*<sup>2</sup>, *g'*, *g*<sup>2</sup>, *l'*, and *l*<sup>2</sup> inserted therein.

Witnesses: ALFRED E. PARKS.

JAMES N. BREWSTER,  
THOMAS CHATWIN.