

L. BRADLEY.
ELECTROMAGNET.

No. 29,761.

Patented Aug. 28, 1860.

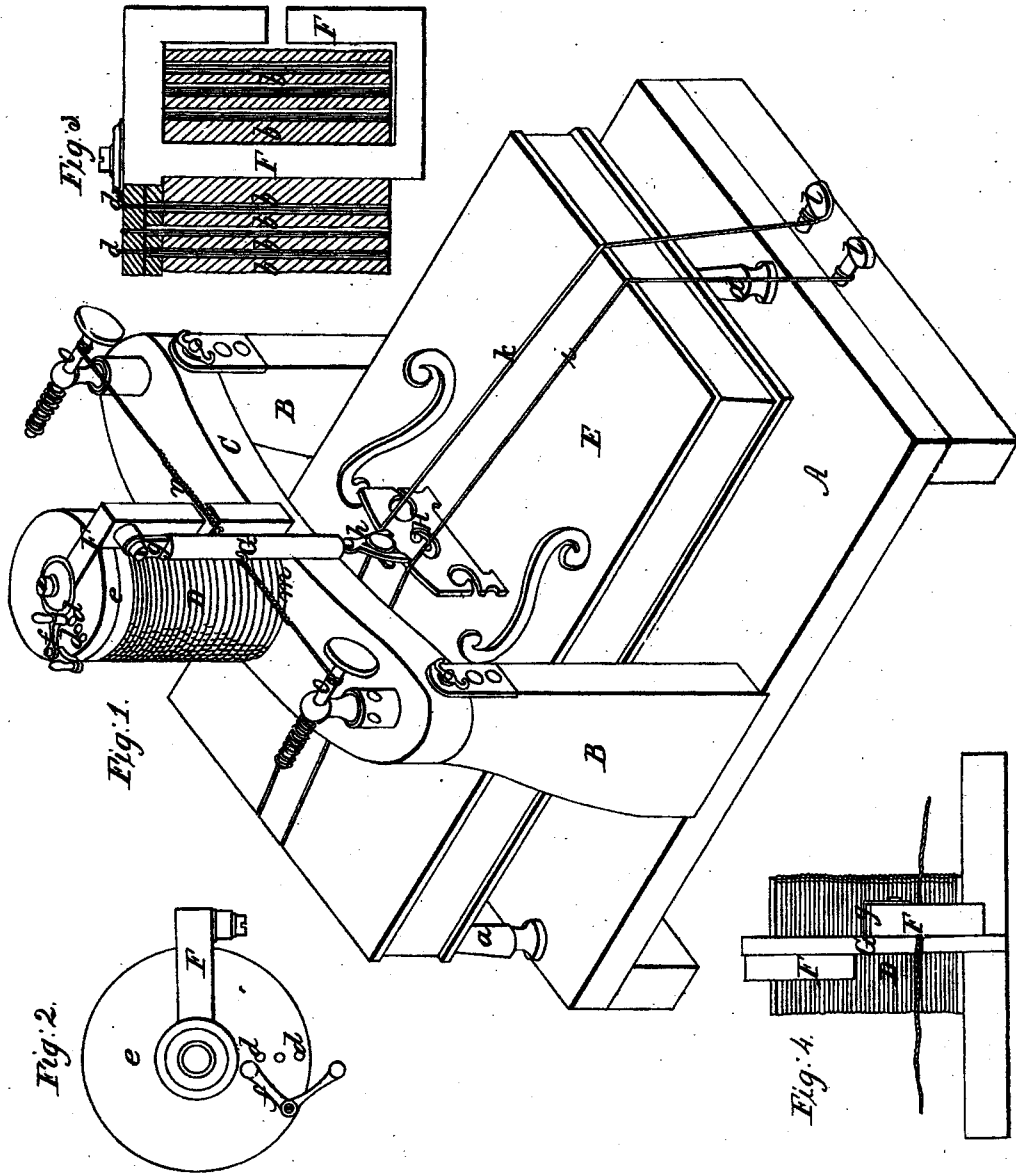

Witnesses:
Augustus Folders
J. R. Smith

Inventor:
L. Bradley by his
attorney
J. Southgate Smith

UNITED STATES PATENT OFFICE.

L. BRADLEY, OF NEW YORK, N. Y.

IMPROVEMENTS IN TELEGRAPHIC APPARATUS.

Specification forming part of Letters Patent No. 29,761, dated August 28, 1860.

To all whom it may concern:

Be it known that I, L. BRADLEY, of the city, county, and State of New York, have invented certain new and useful Improvements in Electro-Magnets, of which the following is a full, clear, and exact description, reference being had to the accompanying drawings, forming part of this specification, in which—

Figure 1 represents a perspective view of an electro-magnet embracing my improvements. Fig. 2 represents a plan of the magnet. Fig. 3 represents a vertical section on the line *x x* of Fig. 2. Fig. 4 represents a modification in the arrangement of the legs of the magnet and armature.

The objects of my improvements in electro-magnets are; to increase the power of the magnet and also its action on the armature without increasing the quantity of helical wire; to give greater freedom and ease to the movement of the armature and to increase its capacity to make a greater number of contacts in a given time; and, also, to arrange the helix so as to increase or diminish the power of the magnet as required and to give greater distinctness to the sound produced by the strikes of the armature in its vibrations.

My invention for effecting these objects consists, first, in constructing the core of the helix so as to pass through the center of the coil, around and in close proximity to its outer surface, with the poles of the magnet in close proximity to each other on the outside of the coil, by which means a more powerful and active magnet is produced with a less coil than in the old construction, in which the magnet only passes through the center of the coil without extending around its outer surface; second, in arranging the armature in line with the legs of the magnet and in close proximity to the outer surface of the coil, by which means the keeper becomes highly magnetic by direct induction from the coil, so that a mutual attractive power between the armature and the magnet is induced in a higher degree; third, in arranging on either side of the armature tension-strings to act in opposite directions, whereby the quickness of vibration and firmness of contact are greatly increased; fourth, in constructing the helix of a magnet in concentric sections, with conductors connecting one section with another throughout, in connection with a double switch

arranged to form a direct connection between any two sections of the helix, so that one or more sections may be passed over and disconnected from the circuit when required to diminish the power of the magnet and the resistance to the electric current passing through the helix; fifth, in the application of tension-strings in connection with a sounding-board, electro-magnet, and armature, against which the armature strikes, rendering the sound more distinct; sixth, in arranging the armature between the poles of the magnet with its center of motion also between the poles and near the center of its length, by which means the ease and rapidity of its movements are increased and firmer contacts are made.

In the accompanying drawings is represented an electro-magnet embracing my improvements, which consists of a bed-plate, A, to support the different parts. From opposite sides of the bed-plate rise two side pieces, B, connected together by a cap, C, on which rests an electro-magnet, D, and beneath the cap, supported on the bed-plate by feet *a*, is a sounding-board, E.

The magnet consists of a helix composed of a series of concentric sections, *b b*, of insulated wire, through the center of which passes a core or magnet, F, of soft iron, which extends across the ends and over the outer surface of the helix and in close proximity to it, while the ends or poles of the magnet are also brought in near proximity to each other. The concentric sections of insulated wire are connected with each other through projecting knobs *d*, which extend through and a short distance above a non-conducting cap, *e*, covering the end of the helix. Pivoted to this cap is a double switch, *f*, consisting of two arms which are jointed to each other, and so arranged as to be brought in contact with the different knobs connecting the several sections of the helix, so that a direct connection may be made between any two sections composing the helix and the intermediate ones passed over.

The magnet is placed in an upright position and suspended from its upper leg by means of thin metallic spring *g*, is a pendent armature, G, which is arranged in close proximity to the outer surface of the helix and also to the legs of the magnet.

Attached to the lower end of the armature,

which extends below the helix, is an adjustable fork, *h*, for regulating the length of the vibrations of the armature in closing or breaking the circuit. These forks vibrate between two sounding-wires, *i k*, placed at a proper distance apart and firmly confined at one end to the bed-plate or end of the sounding-board, and pass over the top of the sounding-board and rest on a bridge, *H*, just back of the fork of the armature, and are confined at the opposite end to the bed-plate or sounding-board by thumb-screws *l*, so that their tension may be regulated.

To one side of the armature is attached one end of a retracting-spring, *m*, for withdrawing the armature from the magnet and the sounding-wire on that side, and to the other side is attached one end of a counter-spring, *n*, which acts in an opposite direction to that of the retracting-spring. The other ends of these springs are connected by cords with adjusting-pins *o*, by which the tension of the springs is mutually adjusted to each other.

The armature, instead of being arranged, as represented in Fig. 1, parallel to and on the same side of both the legs of the magnet, may be arranged parallel to the legs and pass between them, as shown in Fig. 4, the legs being turned so that the distance between them is sufficient to admit the armature to be placed between and parallel to them, in which case the armature, instead of being suspended at the end, is suspended to vibrate on a center between the two poles of the magnet and near its own center.

The sounding-board *B* in the present instance is made in the form of a rectangular box, but any other form may be given it that is thought best.

In arranging this electro-magnet for use the retracting and counter springs acting upon the armature are adjusted so as to place the retracting-spring in a higher state of tension than the counter-spring, and the fork attached to the end of the armature is also adjusted between the wires to regulate the length of the vibration of the armature in closing and breaking the circuit. The switch-bar is also adjusted so that the current will pass through a greater or less number of sections composing the helix, as may be required to operate the armature, depending upon the length of the main line in connection.

This magnet, in telegraphing, can be used either as a sounder to receive and communicate intelligence by sound alone or as a relay-magnet operating a local circuit. When used for the former purpose the wires of the main circuit are connected with it in the usual manner, and the impulses of the electric current from the circuit cause the armature to vibrate, striking the sounding-wires on either side, and the sound of its beats through the medium of the wires and the sounding-board is intensified, so that the lightest touch is heard with great distinctness, by which means the communication of intelligence with this mechan-

ism is rendered clear and distinct by sound alone without the use of a local circuit. When this magnet is used as a relay the local circuit may be connected with one of the sounding-wires and the magnet in the usual manner by means of screw-cups.

In constructing the magnet so that it not only passes through the center of the helix but extends around the end and over the outer surface, bringing the two poles in close proximity, I have found from repeated experiments that with a much less quantity of wire a more powerful magnet is obtained than in the old mode, in which the magnet only passes through the center of the helix, and which in telegraphing is of great importance, as the resistance to the passage of the electric current through the helix is in the ratio of the length of the wire forming the helix.

Another advantage obtained by this construction of the magnet is that it is demagnetized quicker and more freely than in the old mode, and which is absolutely necessary in order to communicate intelligence with great rapidity.

In arranging two springs acting in opposite directions on the armature, one of which is placed in a greater state of tension than the other, a more rapid vibration of the armature is obtained than by the use of a single spring, owing to the fact that springs in a high state of tension vibrate more rapidly than in a low state, and which this arrangement admits of without increasing the power required to operate the armature, as the increased power exerted by the spring in a high state of tension is counteracted by the opposite spring; and, moreover, by this arrangement firmer connections are made in closing the circuit than with the single spring.

In arranging the helix in concentric sections so that one or more of these sections may be thrown out by means of the switch, which, on being placed on the knobs, the current follows as the line of least resistance instead of passing through the intermediate sections, the power of the magnet may be increased or diminished with great facility and instantaneously adapted to long or short circuits, and thus relieve the line of all unnecessary resistance.

I do not confine myself to the precise construction, form, or arrangement of the parts as described, as these may be varied without departing from the spirit of my invention. The springs operating the armature may be varied in form, construction, and arrangement, provided they act in opposite directions on each other, so that one may be placed in a higher state of tension than the other to increase its velocity of vibrating, while its dynamic force is counteracted by the other, and instead of acting directly on the armature they may be made to act on the armature-lever used in ordinary machines. The number of sectional coils composing the helix may be increased or diminished as circumstances may

require in constructing different-sized magnets. The armature, when suspended so as to vibrate on its center, may be arranged either in an upright or horizontal position, and when used with the horseshoe-magnet and helix, instead of vibrating in a plane parallel to the legs, may vibrate on a center between the legs and in a plane perpendicular to the side of the magnet.

Having thus described my improvements in electro-magnetic machine, what I claim therein as new, and desire to secure by Letters Patent, is—

1. The combination of a helix with a core arranged to pass through its center and around and in close proximity to its surface with the poles, also in near proximity to each other, for the purpose set forth.

2. The combination of a magnet constructed substantially as described with a keeper arranged parallel to the legs of the magnet and in close proximity to the periphery of the helix, for the purpose set forth.

3. The combination of the armature or its equivalent for breaking and closing the circuit with two springs arranged to act on each other in opposite directions, for the purpose set forth.

4. The combination of a sectional helix with a double switch, arranged substantially as described, for the purpose set forth.

5. The combination of a vibrating armature or its equivalent in closing and breaking circuits, with a sounding-board and tension-wires, arranged substantially as described, for the purpose set forth.

6. The combination of an electro-magnet with an armature suspended by its center between the poles of the magnet so as to come in contact with both poles at the same time.

In testimony whereof I have subscribed my name.

L. BRADLEY.

Witnesses:

F. S. SMITH,
JOHN S. HOLLINGSHEAD.