

J. M. BATCHELDER & M. G. FARMER.
 MODE OF MAKING BATTERY CONNECTIONS WITH ELECTROMAGNETIC
 COILS ON TRAVELING CARRIAGES OF TELEGRAPHIC REGISTERS.

No. 10,496.

Patented Feb. 7, 1854.

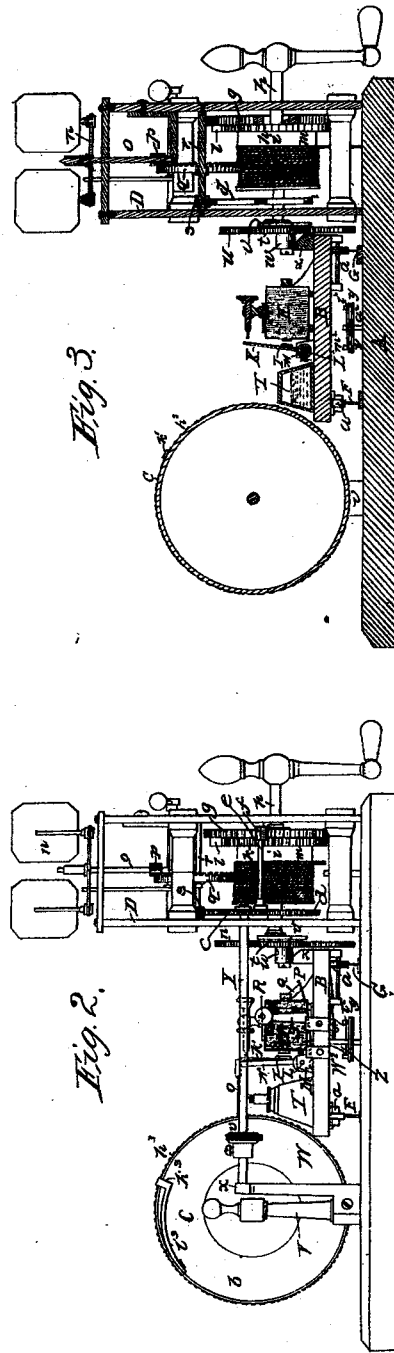
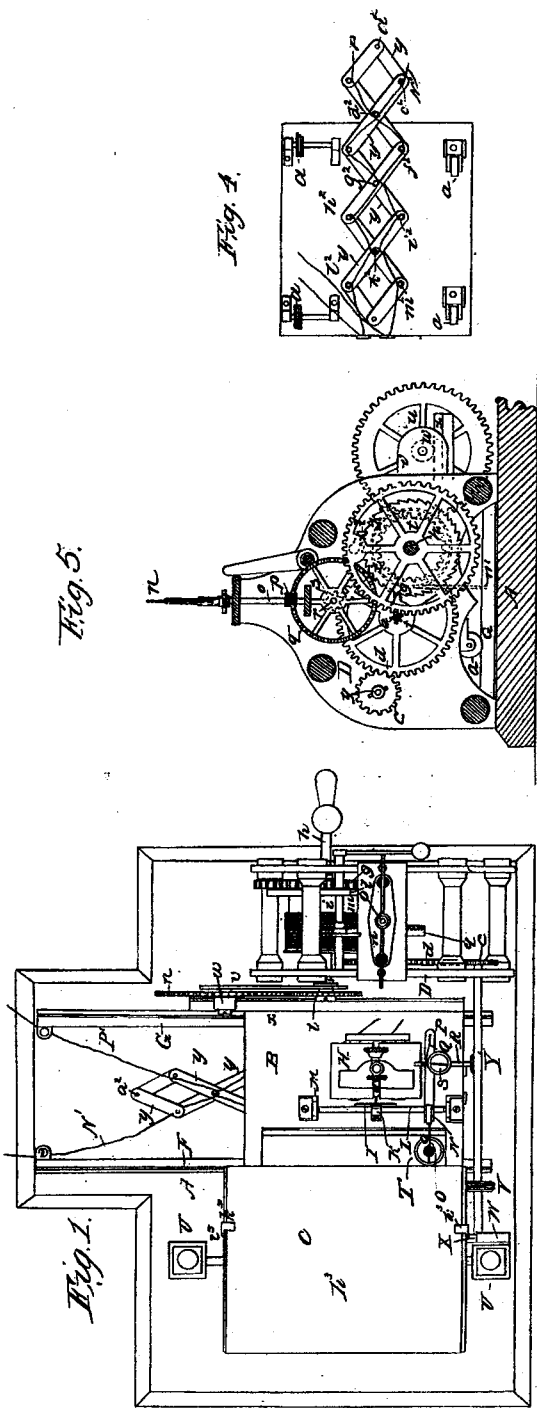

Fig. 1.

Fig. 2.

Fig. 3.

Fig. 4.

UNITED STATES PATENT OFFICE.

J. M. BATCHELDER, OF CAMBRIDGE, AND M. G. FARMER, OF SALEM, MASS.

IMPROVEMENT IN THE MODE OF MAKING BATTERY CONNECTION WITH AN ELECTRO-MAGNETIC COIL ON THE TRAVELING CARRIAGE OF A TELEGRAPHIC REGISTER.

Specification forming part of Letters Patent No. 10,496, dated February 7, 1854.

To all whom it may concern:

Be it known that we, JOHN M. BATCHELDER, of Cambridge, in the county of Middlesex, and MOSES G. FARMER, of Salem, in the county of Essex, and State of Massachusetts, have invented a new and useful Improvement in Electric Telegraphs or Telegraphic Registers for Reducing and Permanently Recording Telegraphic Signals; and we do hereby declare that the same is fully described and represented in the following specification and the accompanying drawings, letters, figures, and references thereof.

Of the said drawings, Figure 1 denotes top view of our invention. Fig. 2 is a front-side elevation of it. Fig. 3 is a longitudinal and vertical section of it, taken through the middle of the carriage to be hereinafter described. Fig. 4 is an under-side view of the carriage and the system of progressive levers applied to it for the purpose of maintaining the connection of the circuit-wires with the electro-magnet of the instrument. Fig. 5 is a vertical and transverse section taken through the clock-work apparatus or mechanism by which the motions of the carriage and the recording-cylinder are produced, the said section being made to represent the main driving-gear on the crank-shaft.

The operative parts of the mechanism are supported, on a suitable base-board or table, A, at or near one end of which is placed the machinery that gives motion to the traversing platform or carriage B, and to the recording-cylinder C, the latter being arranged near the other end of the board A.

The train of wheel-work which operates the platform and cylinder is mostly contained within a suitable frame, D, and should be so constructed and arranged that when put in operation it may be capable of giving to such parts their proper movements, as will be hereinafter described.

We generally move the platform or carriage B on its rails F and G about one-twelfth of an inch in the same time that the cylinder C is made to perform one revolution. We do not, however, confine our invention to such relative velocities of movement of the cylinder and carriage, as others may be adopted.

The rails F G before mentioned are arranged parallel to each other and made to

rest on and extend above the base-board A. The carriage B, by means of four or any other suitable number of wheels, *a a*, &c., is made to rest and move on these rails, which are constructed of such length as to permit the carriage to traverse a distance equal to the length of the cylinder C.

The carriage B supports an electro-magnet, H, that has an armature, I, placed in front of its poles and affixed to an arm, K, made to extend upward from a rocker-shaft, L, which is supported in bearings M M situated on the top of the carriage. Another arm, N, projects upward from the shaft L and supports a stylus or wire, O, which is pressed toward the cylinder C by the action of a spring, P, one end of which is attached to the lower part of the arm N, while the other is affixed to a cord, Q, that is wound on a windlass-pin, R, sustained by a standard or post, S. By turning the windlass-pin so as to wind the cord on it the stylus is pressed with greater force towards the cylinder, and, therefore, by means of the windlass-pin and cord the pressure of the stylus against a sheet of paper wrapped around the curved surface of the cylinder may be regulated.

Under the stylus a spirit-lamp, T, is placed, as seen in the drawings, its flame being directed upon the stylus so as to heat it while the machine is in operation.

The cylinder or barrel C has its journals supported by two posts, U U. One end of it is covered around in a circular path with india-rubber, leather, or other equivalent, as seen at *b*. Against this a milled wheel, V, is pressed by the action of a spring, W, which is made to bear against a movable standard or arm, X, that sustains one end of the horizontal shaft Y on which the wheel V is fixed. On the other end of the shaft Y is a spur gear-wheel, *c*, that engages with a larger gear-wheel, *d*, affixed on an axle, *c*. This axle carries a toothed pinion, *f*, which engages with the main driving-gear, *g*, that is placed and made to run loosely on the crank-shaft *h*.

Fixed on the crank-shaft is a barrel or drum, *i*, and a ratchet-wheel, *k*. A spring-pawl, *l*, applied to the side of the gear *g* engages with the ratchet-wheel. A cord, *m*, is wound around the barrel *i*, and has a weight attached to its lower end.

A fan-regulator, *n*, is affixed on the top of a vertical shaft, *o*, arranged as seen in the drawings. A pinion, *p*, on the shaft *o*, is made to engage with a toothed wheel, *q*, fixed on a shaft, *r*, on which there is a pinion, *s*, that is made to engage with the gear-wheel *d*.

A gear-wheel, *t*, is fixed on the inner end of the main shaft *h*, and is made to engage with another gear-wheel, *u*, that is supported on the outer end of a rocker-arm, *v*, which turns on the shaft *h*. A small wheel, *w*, is attached to the wheel *u*, and is turned with and by it and made to rest on a rail, *x*, elevated on the platform or carriage B, as seen in the drawings. The pressure of the wheel on the rail and the rotations of the wheel will cause the carriage to be moved on its rails in manner as required.

To the under side of the carriage B one end of a system of progressive levers, *y y*, &c., is jointed or made to turn on a pin, *z*, the other end of such system being jointed to the base-board A, or made to turn on a pin, *a*², the whole being arranged and applied together as seen in the drawings.

A bottom view of the system of levers is shown in Fig. 4. Their joint-pins *b*² *c*² *d*² *e*² *f*² *g*², &c., extend above the levers a short distance.

The battery or circuit wires N' P' are fastened, respectively, to the pins *b*² *c*²; thence they both extend to and are wound around the pin *d*²; thence they respectively extend to and are wound around the pins *e*² *f*²; thence they are both wound around the pin *g*², and so they continue in the above manner to be applied to all the joint-pins of the series. Finally they are extended to and wound around the magnet or connected with its coil in the usual way. By means of this contrivance, the wires are prevented from being kinked or getting under the wheels of the platform during its movements. When the current of electricity is suffered to flow through the coil of the magnet the armature will be drawn towards the magnet, so as to cause the stylus or wire to be drawn away from the cylinder. As soon as the circuit is broken the stylus is returned against or pressed towards the cylinder by the retractile power of the spring P.

Around the curved surface of the cylinder we place or wrap a sheet, *h*³, of paper or other suitable material previously dyed or colored, or chemically prepared, or having a dyed surface capable of being either changed in color or decolorized by the action of heat, or instead thereof we so prepare the surface of the cylinder, or apply to it such a chemical or other preparation or solution, as will be capable of being either changed in color or decolorized by the action of heat. Many such solutions or chemical matters are known to chemists. The ordinary rose or pink colored tissue-paper of commerce will generally be found to be suitably dyed or prepared for our purpose.

Besides changing the color or decolorizing a surface or chemically-prepared material, our

instrument is capable of producing marks or telegraphic signs by burning or charring a piece of paper or other proper material. In this respect it differs essentially from the electro-thermic or electro-caustic telegraph invented by George H. Horn, and patented on the 25th day of June, A. D. 1850, for in the latter a current of electricity flowing through a stationary fine platina wire heats the wire to a burning or charring heat, whereas in our telegraphic instruments the marking-stylus or burning-wire is heated by a lamp or other means, and is moved towards and away from the paper.

In our invention or machine the wire may be heated by a separate or secondary current of electricity made to flow through it, such wire being moved or actuated by the agency of a main circuit. This combination of parts differs essentially from the electro-thermic telegraph of the said Horn, for in Horn's invention there is no movement of the stylus or wire toward or from the paper by the agency of an electric or electro-magnetic current. The burning-wire of Horn's telegraph is perfectly stationary, and is alternately heated and cooled during the passage of the paper over it. In our instrument the wire when heated by an electric current is not alternately heated and cooled during its operation, but is constantly maintained at a burning or charring heat or suitable temperature, and by means of a secondary battery and circuit which has no such connection with the primary circuit as a secondary and primary circuit must have when used in Horn's invention. In this latter the primary electro-magnetic circuit must be employed to close the secondary circuit; but in our invention it has no such connection with the secondary circuit, it being independent of it in its operation, and used either to draw the heated stylus away from or towards the paper or cylinder as circumstances may require.

Our invention differs also from that wherein the telegraphic marks are produced on paper or a dyed or chemically-prepared surface by the direct contact of the electric spark or current, or acid produced thereby, when the said spark or current is made to operate as it does in Bain's telegraph.

We do not confine our invention to the above-described modes or machinery for imparting to the platform B and the cylinder C their respective proper movements, as various other kinds of mechanism may be used for such purpose.

At each end of the cylinder C a spring, *i*², is attached, the same being provided with a lip, *k*³, which is so bent as to rest upon and overlap the ends of the sheet of paper *h*³ and confine the paper in place on the cylinder.

The paper we have found useful for our telegraphic instruments is known in commerce by the name of "English tissue paper," of which various colors may be used, but that which is of a pink shade we have found best adapted

to the purpose, as the discoloration produced by the heat of the marking-wire is of a yellow tint, and is distinctly seen on a pink ground.

It will be observed that the rotary motion of the cylinder and the horizontal motion of the recording-wire cause the line of the marks and dots to assume a helical form. When the sheet of paper is unwrapped from the cylinder these lines will be parallel and may be read like common writing—that is, from left to right and from the top to the bottom of the page or sheet.

To make the record, we prefer to employ the closed circuit in such manner as to cause it to draw the heated wire away from the paper, using a spring, or its equivalent, to carry the wire back and keep it up to the paper.

In making the signals, we employ a break-circuit key as in other electric telegraphs. As the slightest contact of the heated wire with the paper is generally sufficient to produce either a legible mark or discoloration, and as very little force is required to withdraw the wire from the paper, the circuit, generally speaking, will have ample power to work the instrument without the intervention of a local or secondary circuit, and a magnetic connection of the two, such as will enable the primary circuit to close the local or secondary one.

In our invention the working-wire may be held back or drawn from the paper by the action of a spring, or its equivalent, and brought or forced in contact with it by the action of the electro-magnetic circuit; and we would also

remark that instead of an electro-magnet and armature to work the heated wire a deflecting needle and coil may be employed.

From the above it will be seen that a principle of our invention is the application of a heated wire to a chemically-prepared paper or dyed surface, substantially as specified, so as to produce telegraphic marks or signals either by the simple change of color or decolorization of such paper or surface without boring into or through it, as does the electro-thermic or electro-caustic telegraph of Horn; also, that it is a principle of our invention to produce such mark or marks by charring or burning into a surface, or through paper or other proper substitute by the employment of a heated wire, and by an electro-magnetic circuit, making it movable toward or away from the moving paper or substance on which the marks are to be made.

We claim—

The combination of the system of progressive levers with the battery-wires, the base-board, and movable platform, so as to operate substantially as specified and for the purpose set forth.

In testimony whereof we have hereto set our signatures this 8th day of February, A. D. 1853.

JOHN M. BATCHELDER:
MOSES G. FARMER.

Witnesses:

E. H. EDDY,
JOHN NOBLE.