

J. M. BATCHELDER.
INSULATOR FOR TELEGRAPH WIRES.

No. 8,418.

Patented Oct. 14, 1851.

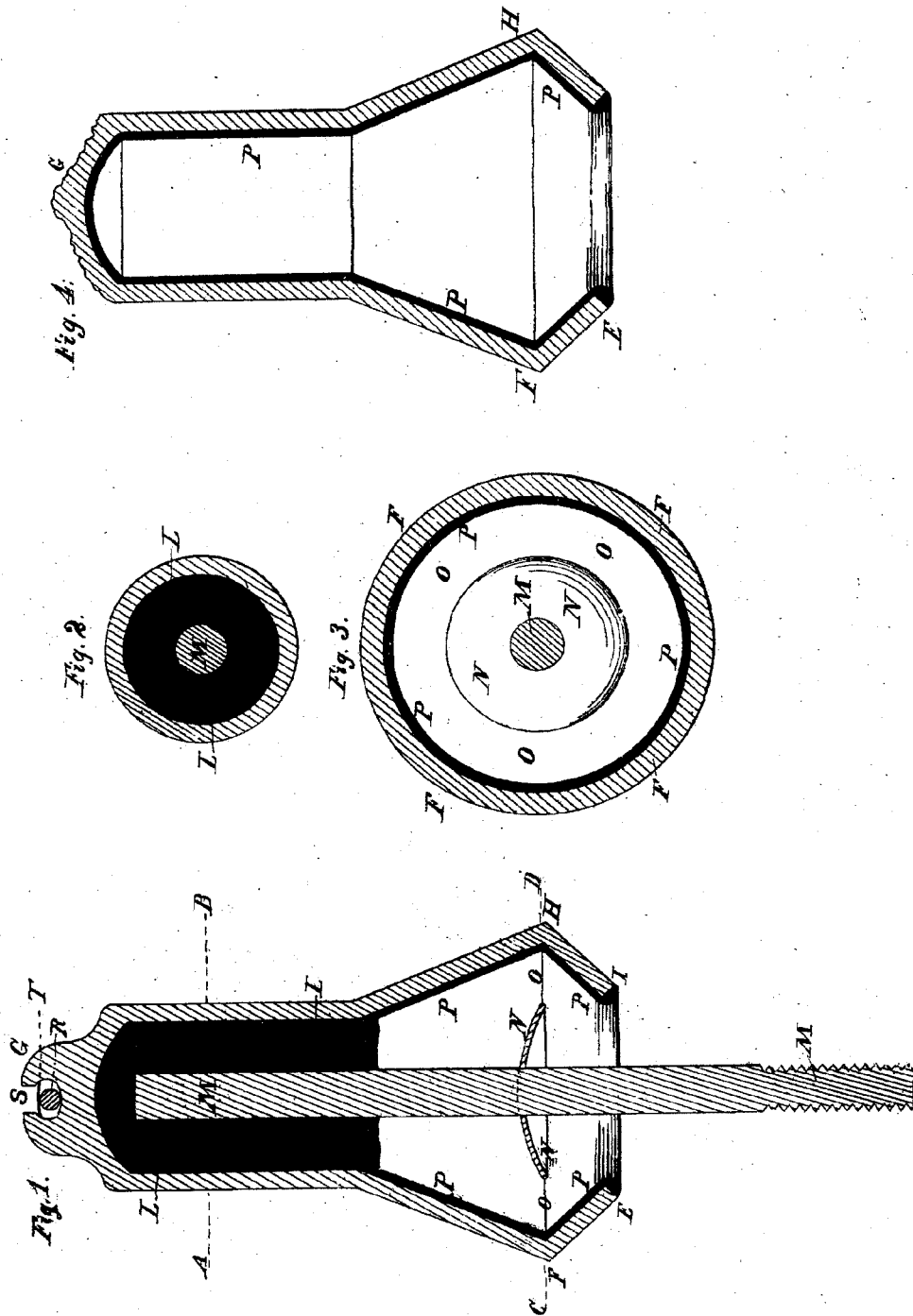

282

UNITED STATES PATENT OFFICE.

JNO. M. BATCHELDER, OF CAMBRIDGE, MASSACHUSETTS.

IMPROVEMENT IN INSULATORS FOR TELEGRAPH-WIRES.

Specification forming part of Letters Patent No. 8,418, dated October 14, 1851

To all whom it may concern:

Be it known that I, JOHN M. BATCHELDER, of Cambridge, in the county of Middlesex and State of Massachusetts, have invented a new and Improved Insulator or Wire-Holder, for the purpose of insulating and supporting the wires of the electro-magnetic telegraph; and I do hereby declare that the following is a full, clear, and exact description of the construction and use of the same, reference being had to the annexed drawings, making a part of this specification, in which—

Figure I is a vertical section of the instrument. Fig. II is a transverse section on the line A B. Fig. III is a transverse section on the line C D. Fig. IV is a section of the cup, showing the lining of glass or other vitrified substance.

The object and design of this invention is to afford a convenient and suitable holder or supporter for the wires of the electro-magnetic telegraph, and to secure a more perfect insulation of the wires, especially during rain-storms, than has heretofore been effected.

A hollow cup, E F G H I, Fig. I, made of iron or other metal, is filled to about one-half of its depth with glass L L or other substance that is a non-conductor of electricity, in which is embedded a metallic bar or shank, M, usually made of wrought-iron, by which the insulator is supported. This shank or center bar has upon its lower end a screw, which enters the telegraph-post, or it may be pointed and bent at right angles and driven into the post. The cup, the glass, and the center bar, as above described, are commonly known and used.

My improvement consists—

First, in the peculiar mode of forming the base or lower part of the cup—to wit, the circular walls or sides of the cup, instead of being open or bell-mouthed, are made to approach toward the center bar or axis of the cup, as shown at E E and H I, the angle of the sides with the axis being about forty-five degrees. As the wind and rain strikes upon this bent lip or re-entering angle, it is directed downward and prevented from moistening the interior surface of the cup.

Second, an annular disk, washer, or diaphragm, N, Figs. I and III, having its lower surface concave and its upper surface convex, is

attached to the center bar, M, at about half an inch above the bottom or lip of the cup E I. This disk is of such a size as to leave an annular space, O, between the disk N and the interior surface of the cup, the space being of sufficient breadth to prevent the passage of electricity between the disk and the cup. The disk may be of sheet-iron, glass, or other material. It is not necessary that it should be a non-conductor of electricity. Its principal use is to protect the interior of the insulator from moisture.

My third improvement consists of an enamel or glazing of porcelain, glass, or other vitrified non-conducting substance, applied to and in contact with the metallic surface of the cup, as shown at P, Figs. I, III, and IV. This covering or lining commences at the surface of the solid glass L, and is continued to the open end or lip of the cup at E I. In this manner I secure a large insulating-surface with a very thin coating of glass or other non-conducting substance, while at the same time it is so placed in contact with the surface of the metal as to prevent it from being broken or otherwise injured. This non-conducting surface may be applied to the metal in the manner commonly known to and practiced by the manufacturers of articles for culinary and other purposes, styled "enameled ware;" or, when glass is used to give this surface, it is most conveniently applied by the process of "blowing." A proper quantity of melted glass is taken from the melting-pot by the blow-pipe and placed within the cavity of the cup. The glass is then distended by blowing through the tube until it fills and adapts itself to the shape of the interior of the cup. The blowing-pipe is then detached from the glass, and the glazed cup is placed in the leer, where it is annealed in the usual manner. In some cases I prefer to enamel or glaze the whole of the inside of the cup, as shown in Fig. IV, and afterward "cast in" the glass to secure the shank or center bar, as above described.

The telegraph-wire R, Fig. I, is passed through a slot or aperture, S, in the cup, and is secured in place by a tapered wedge, T, made of sheet-iron; or it may be fastened to the cup by a short piece of annealed wire, or in any other manner. As the electricity passes upon

the wire, the cup is also charged, while the non-conducting surface of glass, porcelain, or other vitrified substance prevents the electricity from escaping to the supporting-bar or to the telegraph-post.

What I claim, and desire to secure by Letters Patent, is—

1. The re-entering angle at or near the base of the cup, as described, for the purpose of giving the wind a direction downward, thereby preventing the rain that is driven by the wind from entering the cavity of the cup.

2. The annular disk or washer supported upon the center shank or rod, and so placed

within or at the open or lower end of the inverted cup as to prevent the free access of wind and rain to the inside of the cup.

3. I do not claim the mode of embedding the shank in glass cast around it; but I do claim the application of the enamel or glazing of porcelain, glass, or other vitrified non-conducting material to a surface of metal when the same is used for insulating the wires of the electric telegraph.

JOHN MONTGOMERY BATCHELDER. [v. s.]

In presence of—

F. L. BATCHELDER,

JAS. BENJAMIN.