

S. F. B. MORSE.

3 Sheets—Sheet 1.

Telegraph.

No. 4,453.

Patented April 11, 1846.

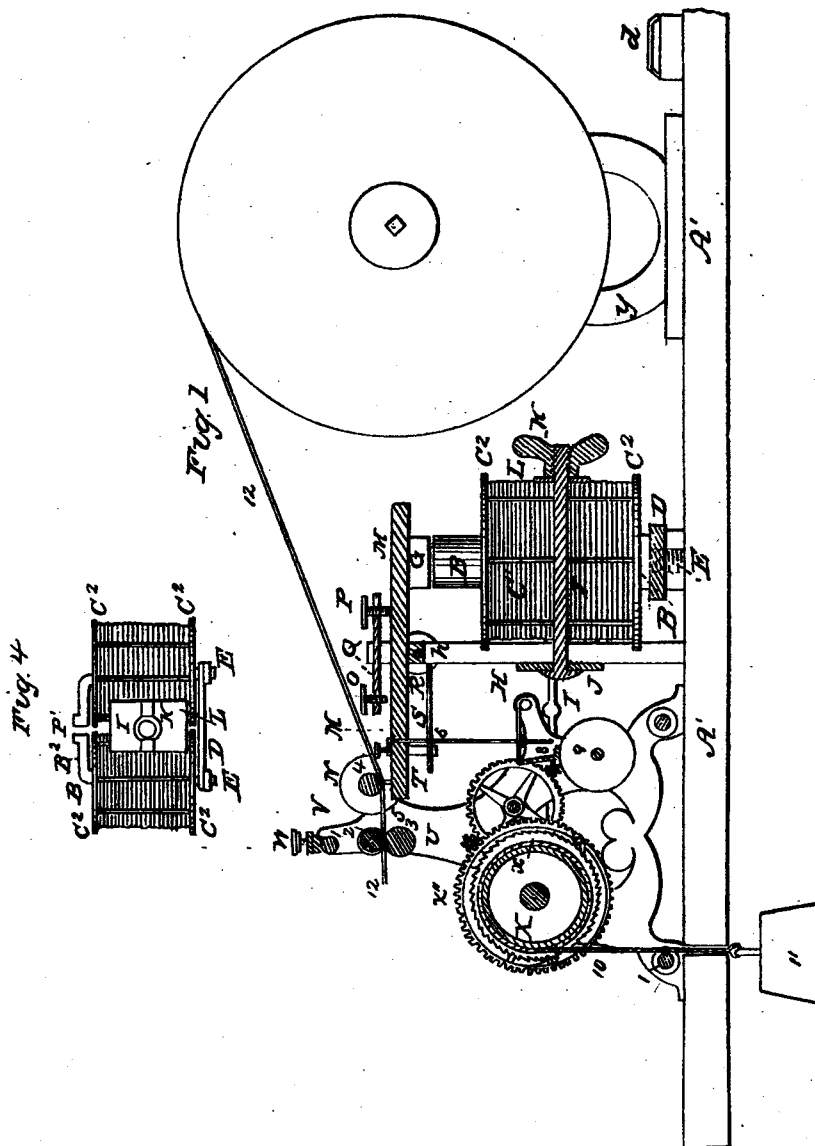

S. F. B. MORSE.

Telegraph.

3 Sheets—Sheet 2.

No. 4,453.

Patented April 11, 1846.

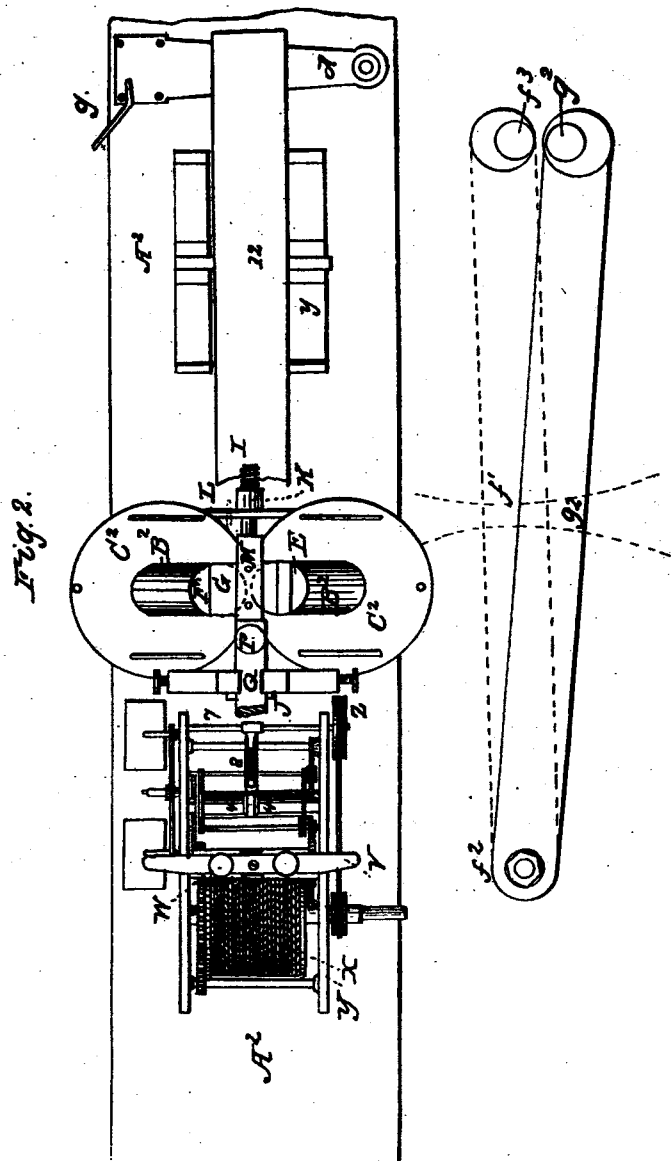

S. F. B. MORSE.

3 Sheets—Sheet 3.

Telegraph.

No. 4,453.

Patented April 11, 1846.

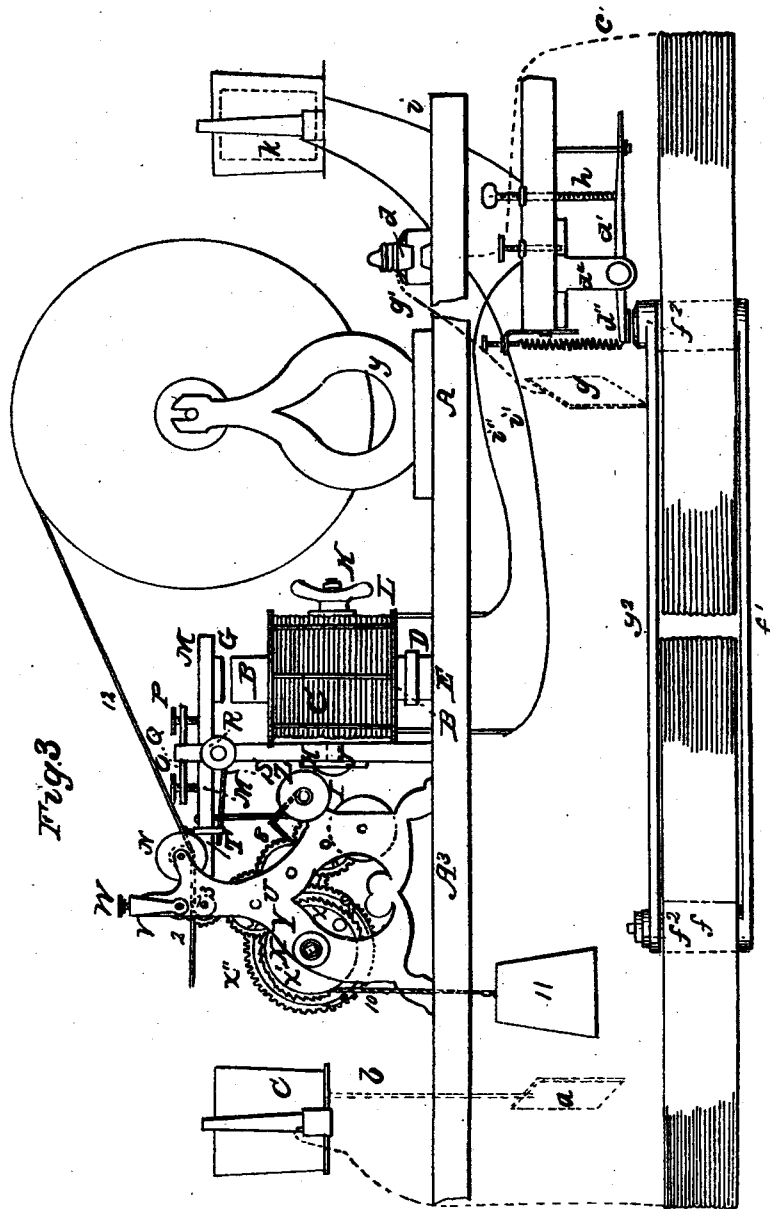

UNITED STATES PATENT OFFICE.

SAMUEL F. B. MORSE, OF NEW YORK, N. Y.

IMPROVEMENT IN ELECTRO-MAGNETIC TELEGRAPHS.

Specification forming part of Letters Patent No. 4,453, dated April 11, 1846.

To all whom it may concern:

Be it known that I, S. F. B. MORSE, of New York, in the county of New York and State of New York, have invented a new and useful Improvement in the Electro-Magnetic Telegraph; and I do hereby declare that the following is a full, clear, and exact description of the construction and operation thereof, reference being had to the accompanying drawings, in which—

Figure 1 is a vertical longitudinal view through the machine. Fig. 2 is a top plan. Fig. 3 is a side elevation.

The construction of my apparatus is as follows: In the section Fig. 1, A represents the base, which is an oblong plank to which all of the other parts are affixed. Near one end of said base are two upright standards. (Shown in the figures and lettered *y*.) These standards are represented by harp-shaped castings, which are placed a little distance apart and support the journals of a short cylinder near their top, around which a strip of paper, 12, is wound, of any length, and from it is supplied to the machine, as hereinafter described.

Near the center of the base A is situated the electro-magnet of the register, which is constructed as follows: Two round bars of soft iron are each placed in a coil of insulated copper wire, C, the lower ends of said bars B' being connected by a cross-bar, D, extending from one to the other, through which they pass, and to which they are secured by screws, which are screwed onto them. The upper ends of these bars above the coils curve inward toward each other, coming nearly together without touching, as shown at B², Fig. 4, and the extreme ends are turned upward, as shown at F', same figure.

Just in front of the coils C, above named, there is affixed to the base an upright standard, H, through which a bolt, I, is put horizontally, with its head against a plate, J, between it and standard H. This bolt passes through between the two coils C, and also through a cross-bar, L, that extends from one coil to the other. On its end a screw is cut, on which a nut, K, is screwed, which secures the two coils and the soft-iron bars firmly in their places. Each of the coils of wire have wooden heads

or cheeks above and below, with binding-wires extending from one to the other, for the purpose of keeping the wire together.

On the top of the standard H there is a cross-bar, Q, permanently attached to said standard, and having in each end a thumb-screw, (lettered O and P,) the ends of which extend down nearly to a lever, M M, directly under said bar Q, which I denominate the "pen-lever." One arm of this lever projects over the soft bars above named, where an armature, G, of soft iron is attached to it, that extends over the surface of the ends of both bars B² of the electro-magnet, as shown in the plan, Fig. 2. To the other end of the lever three, more or less, points, 5, are affixed, that project upward toward a steel roller, 4, directly under the center thereof, as hereinafter described.

The extent of the vibration of the lever M is regulated by the thumb-screws O and P, above named, its pivot *h* being in the standard H. The screw O is for limiting the upward motion of the pen or points 5, and P their downward motion, a spring, 8, being used to draw them down.

A suitable frame is secured to the same base A as the other parts above described, which contains the clock-work for supplying the paper from the roll. Said clock is composed of a cylinder or barrel, 2, on which a cord, 10, is wound, to which a weight, 11, is suspended. On this barrel, at one end, is a ratchet-wheel, 2', and on the same shaft as the barrel there is a spur-wheel, 2'', with a spring-click, similar to a common clock. This wheel connects, by means of a multiplying-gearing, with the cylinder 3, upon which is pressed a cylinder, 2, by means of a spring, V, which passes over the top of the frame, its ends turning down and resting on the journals of cylinder 2, Figs. 2 and 3, and holds down the upper roller. The pressure of this is regulated by screws W on top. These cylinders draw the strip of paper 12 between them, after it has passed under a cylinder, 4, placed over the pens above described, in which cylinder are grooves 4', cut directly opposite the points.

In addition to the above-described machine, there is what I denominate a "receiving-magnet," of the following construction and use. It is

represented in Figs. 2 and 3, and consists of a bar of soft iron, f^1 , the two ends $f^2 f^3$ of which are turned up at right angles, and said ends are made larger in diameter than the lower horizontal part, f^1 , which may be flat. On the upper end of one of the uprights, f^2 , is bolted a horizontal bar, g^2 , that extends out to a point just beside the other upright, f^3 , (more clearly shown in the outline Fig. 2,) and its end turns up at the same distance from f^2 as the end of f^3 . The upper end of the upright f^3 and bar g^2 are on a level with each other, and they are chamfered off on the sides from each other, so as to have the face of the upper ends smaller than the body of the bars and adjacent to each other. Around each of the uprights $f^2 f^3$ there is a large flat coil of wire consisting of a wire of considerable length, say one mile, more or less, in each coil. These coils connect with a battery, c , Fig. 3, at the other station by a wire from one of the coils, and with the ground as a conductor to the other, as hereinafter described. The circuit can be broken or closed by an apparatus consisting of a straight lever or key, d , Figs. 2 and 3, to one end of which one wire, g' , Fig. 3, is connected, and a boss of metal, e , composing the anvil, is attached to the other wire, e' , forming the rest of the circuit. When the hammer on the lever d is brought down on the anvil it closes the circuit, by which the bar $f^2 f^3$ of the receiving-magnet at the opposite station is magnetized. This attracts a keeper or armature, d'' , on the short arm of a straight metal lever, d' , suspended on metal standards d^1 above it, which causes the long arm of said lever to rise and come in contact with a brass adjusting-screw, h , placed above and near its end, to which is attached the wire leading to one pole of the local battery k . The wire i' from the other pole of said battery is connected with the metal standards d^1 that support the journal of lever d' , and thus completes the circuit which has the electro-magnet B in it for writing, by which any amount of power can be obtained that is required to enable the said magnet to draw down the armature G above described, which causes the points 5 to mark on the paper 12. (See Fig. 1.)

To the arm M of the pens a break, S , which is a common plain lever, is attached by means of a connecting-rod, 6 , so as to be raised from a friction-pulley when the pen is made to mark and let off the clock-work attached thereto, which puts the paper in motion. This break S is attached to the shaft 7 placed a little above the friction-pulley 9 that is connected with the clock-work on which said break acts. On the same shaft 7 with the break there is a pulley, z , connected by an endless band with a smaller pulley on the shaft of the barrel on which the weight-cord is wound. This causes the break, when raised by the lever M , slowly to descend till it strikes the friction-pulley 9 and stops the clock-work, after a sufficient quantity of paper has been run off by its action to form the spaces for the longest rests between the

motions of the pen-lever M , and thus keeping the break up till the writing ceases, after which it gradually descends and the machine is stopped.

The red and black lines, Fig. 3, show the relative positions of the apparatus in connection with a circuit of wire.

a is a copper plate buried in the ground, from which a wire, b , ascends to a battery, c . This I denominate the "main battery." From thence the wire extends to a receiving-magnet, f , described in a former section, and represented at f , Figs. 1 and 3. From thence a wire, e' , is continued to the opposite station, and is there connected with the anvil e of the key d , as above described, and thence to another plate of copper, g , in the ground. Connecting this circuit by means of the key d , magnetizes the receiving-magnet and causes the lever d' to move, which closes the circuit of wire i connected with a local battery, k , and magnetizes the soft bars B of Fig. 3, acting on the pen-lever, which causes it to mark on the paper.

The economy of the galvanic power by the introduction of the receiving-magnet is obvious. When the extent of the telegraphic line is very great the resistance to the passage of the galvanic current is proportionably increased, and an enormous battery would be required to operate the pen by means of the register or local magnet, which is of small dimensions and has a comparatively short extent of wire around it; but I have discovered that by using a very long coil of wire, as in the receiving-magnet, there is a sufficiently powerful magnet produced (notwithstanding the length of the telegraphic line may be very great) by means of a small galvanic battery. The same extent of galvanic battery that would produce no available magnetism in the register-magnets charges the receiving-magnet to such an extent as to enable me to produce motion, and thus at pleasure to make and break the circuit of the small local battery, which, being on the spot and charging the register-magnet, gives me perfect control over it and the apparatus connected with it. Thus I resort to two magnets and two batteries, of such relative characters as I have described, to effect a communication through any distance desired without increasing to any considerable degree the size of the main galvanic battery, which is in itself a great source of expense.

What I claim as my invention, and desire to secure by Letters Patent, is—

1. The receiving-magnet, or a magnet having a similar character, that sustains such a relation to the register-magnet, or other magnetic contrivances for registering, and the length of current or telegraphic line as will enable me to accomplish, with the aid of a main galvanic battery and the introduction of a local battery, such motion or power for registering as could not be obtained otherwise without the use of a much larger galvanic battery.

2. The use of a local battery and magnet, in combination with a battery and magnet connected with the main line or lines of conductors, for the purpose above specified.

3. The combination of the apparatus connected with the clock-work for setting off the paper and stopping it with the pen-lever M.

4. The combination of the points affixed in the pen-lever with the grooved roller N for marking on paper, as above described.

SAM. F. B. MORSE.

Witnesses:

ALFRED VAIL,
J. J. GREENOUGH.