

# EARLY ELECTRIC TELEGRAPHS.

## CHAPTER IX.

Suggestions of Science—The Telegraph of Lomond—Reizen's and Dr. Salva's Electric Spark Telegraph—Baron Schilling's, Gauss and Weber's, and Alexander's Telegraphs.

### SUGGESTIONS OF SCIENCE.

THE various discoveries in the sciences, made from time to time, developed the idea of an electric telegraph. With many of the discoverers, nothing more was done by them toward the production of a practical telegraph, than suggesting to others the application of the sciences to the arts, which, in their opinion, would accomplish the great achievement. Philosophers dislike to vend to the world, commercially, their discoveries. They remove the coverings from the long-closed vaults containing the hidden treasures of a mysterious providence; and as soon as they catch a single gleam from the brilliancy of the gem, the world is informed of it. The myriads of discoveries of the present age compose a galaxy more brilliant in glory than those of any other century.

Among those who aided by developing science, suggestive of the telegraph, may be mentioned Prof. Henry, of America, who, in 1830, wrote an article, which was published in Silliman's Journal, in 1831, in which he stated "the fact, that the magnetic action of a current from a trough is, *at least*, not sensibly diminished by passing through a long wire, is directly applicable to Mr. Barlow's project of forming an Electro-Magnetic Telegraph, and also of material consequence in the construction of the galvanic coil." Ampère, Jacobi, Faraday, Sturgeon, and others, have also aided by their discoveries the perfection of the art of telegraphing, as now practically employed throughout the civilized world.

### LOMOND'S ELECTRIC TELEGRAPH.

It is stated in Young's Travels in France (1787, 4th ed., vol. i. p. 79), that a Mr. Lomond had invented a mode by which,

from his own room, he held communication with a person in a neighboring chamber, by means of electricity. He employed the common electrical machine placed at one station, and at the other an electrometer constructed with pith balls. These instruments were connected by means of two wires stretched from one apartment to the other, so that, at each discharge of the Leyden vial, the pith-balls would recede from each other, until they came in contact with the return wire. His system of telegraphic correspondence is not related. We must suppose from the character of his invention, having but one movement, that of the divergence of the balls, and using an apparatus extremely delicate, that his means of communication could not have been otherwise than limited, and required a great amount of time.

The only mode in which it appears possible for him to have transmitted intelligence, seems to be this: a single divergence of the pith balls, succeeded by an interval of two or three seconds, may have represented A. Two divergences in quick succession, with an interval following, may have represented B; three divergences, in like manner, indicated the letter C; and so on for the remainder of the alphabet. Instead of these movements of the pith balls representing letters, they may have indicated the numerals 1, 2, 3, &c., so that with a vocabulary of words, numbered, conducted his correspondence. This appears to be the first electrical telegraph of which we have any account; but does not appear to have been used upon extended lines.

## REIZEN'S ELECTRIC SPARK TELEGRAPH.

In 1794, according to Voigt's Magazine, vol. ix., p. 1, Reizen made use of the electric spark for telegraphic purposes. His plan was based upon the phenomenon which is observed when the electric fluid of a common machine is interrupted in its circuit by breakers in the wire, exhibiting at the interrupted portions of the circuit a bright spark. The spark thus rendered visible in its passage, he appears to have employed in this manner.

Fig. 1 is a representation of the table upon which were arranged the letters of the alphabet, twenty-six in number. Each letter is represented by strips of tin foil, passing from left to right, and right to left, alternately, over a space of an inch square upon a glass table. Such parts of the tin foil are cut out, as will represent a particular letter. Thus, it will be seen that the letter A is represented by those portions of the tin foil which have been taken out, and the remaining portions answer as the conductor. P and N represent the positive and negative

ends of the strips, as they pass through the table and reappear, one on each side of the small dot at *a*. Those two lines which have a dot between, are the ends of the negative and positive wires belonging to one of the letters. Now, if a spark from a charged receiver is sent through the wires belonging to letter *A*, that letter will present a bright and luminous appearance of the form of the letter *A*. "As the passage of the electric fluid through a perfect conductor is unattended with light, and as the light or spark appears only where imperfect conductors are thrown in its way, hence the appearance of the light at those

Fig. 1.

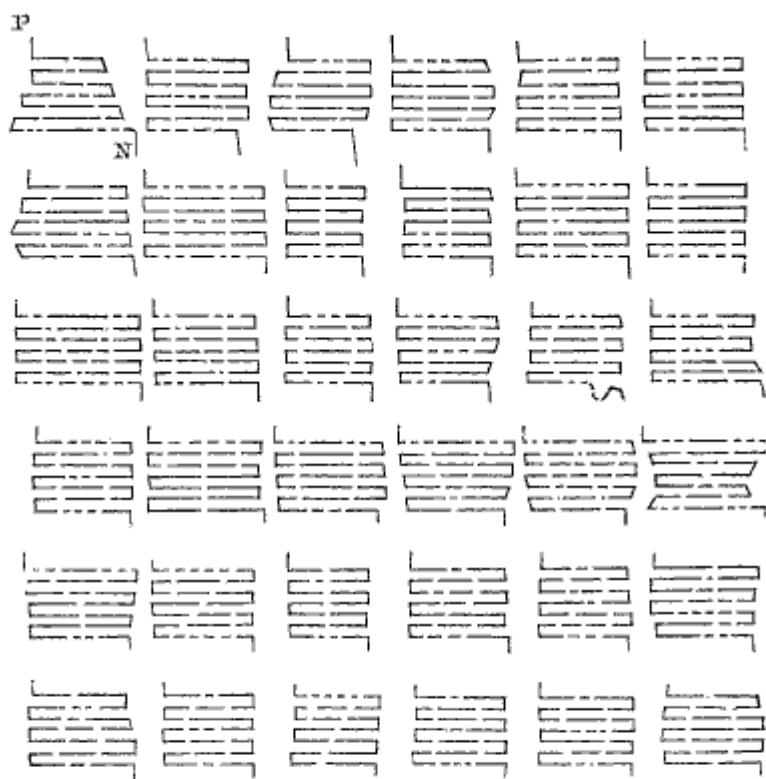

A.  E  
 ABCDEFGHIJKLMNOPQRSTUVWXYZ 1234567890

interrupted points of the tin foil, the glass upon which the conductors are pasted being an imperfect conductor. The instant the discharge is made through the wire, the spark is seen simultaneously at each of the interruptions or breaks of the tin-foil,

constituting the letter, and the whole letter is rendered visible at once." This table is placed at any one station, and the electrical machine at the other, with seventy-two wires enclosed in a glass tube connecting the two stations. He could have operated with equal efficiency by using thirty-seven wires, having one wire for a common communicating wire, or with thirty-six wires, by substituting the ground for his common wire. It does not appear that it was ever operated to any considerable extent.

#### DR. SALVA'S ELECTRIC SPARK TELEGRAPH.

In 1798, Dr. Salva, in Madrid, constructed a similar telegraph as that suggested by Reizen, as will be found on reference to *Vorgt's Magazine*, vol. xi., p. 4. The "Prince of Peace" witnessed his experiments with much satisfaction, and the Infant Don Antonio engaged with Dr. Salva in improving his instrument. It is stated that his experiments extended through many miles of wire. No description of his plans were given to the public.

#### BARON SCHILLING'S ELECTRIC TELEGRAPH.

The following, in relation to Schilling's telegraph, is taken from the *Polytechnic Central Journal*, Nos. 31, 32, 1838:

"Baron Schilling, of Cronstadt, a Russian counsellor of state, likewise occupied himself with telegraphs by electricity (see *Allgem Bauztg*, 1837, No. 52, p. 440), and had the merit of having presented a much simpler contrivance, and of removing some of the difficulties of the earlier plans. He reckoned many variations to the right or left, following in a certain order for a telegraphic sign, as, indeed, in this manner, the needle was strongly varied, and only came to rest gradually after many repeated vibrations; he introduced a small rod of platinum, with a scoop, which dipped into a vessel of quicksilver, placed beneath the needle, and, by the check given, changed the vibration of the needle into sudden jerks. In order to apprise the attendant of a telegraphic dispatch, he loosed an alarm. How much of this contrivance was Schilling's own, or whether a portion of it was not an imitation of Gauss and Weber, the author cannot decide; but that Schilling had already experimented, probably with a more imperfect apparatus, before the Emperor Alexander, and still later before the Emperor Nicholas, is affirmed by the documents quoted."

There may be a mistake in the supposition, that the telegraph of Baron Schilling had been exhibited to Alexander, as that Emperor died in 1825, and there is no evidence to show that the telegraph had been devised by Baron Schilling thus early.

From the report of the "Academy of Industry," Paris, February, 1839, I make the following extract, in relation to the same subject :

"At the end of the year 1832, and in the beginning of 1833, M. Le Baron de Schilling constructed, at St. Petersburg, an electric telegraph, which consisted in a certain number of platinum wires, insulated and united in a cord of silk, which put in action, by the aid of a species of key, thirty-six magnetic needles, each of which was placed vertically in the centre of a multiplier. M. de Schilling was the first who adapted to this kind of apparatus, an ingenious mechanism, suitable for sounding an alarm, which, when the needle turned at the beginning of the correspondence, was set in play by the fall of a little ball of lead, which the magnetic needle caused to fall. This telegraph of M. de Schilling was received with approbation by the Emperor, who desired it established on a larger scale, but the death of the inventor postponed the enterprise indefinitely."

Dr. Steinheil, in his article "upon telegraphic communication," published in the London Annals of Electricity, states, that "the experiments instituted by Schilling, by the deflection of a single needle, seems much better contrived than the arrangement Davy has proposed, in which illuminated letters are shown by the removal of screens placed in front of them."

It would appear that the French report is either incorrect, or that M. de Schilling had two plans in contemplation. His plan as intimated in the first and third extracts, is that of using a single needle in the form of a galvanometer, by means of which he made his signals; for instance, one deflection to the right might denote *e*, two *i*, three *b*; one deflection to the left *l*, two *s*, three *v*. His code of signals would then be devised in the manner shown on the following page.

If, however, his plan was that ascribed to him, by the Academy of Industry, of using thirty-six needles and seventy-two wires, it was exceedingly complicated and expensive, and was similar to that invented by Mr. Alexander, with the exception that Schilling used twice the number of wires.

During my recent residence in St. Petersburg, I endeavored to obtain some further information in regard to this telegraph, but it was not possible to discover more than is embraced above

## BARON SCHILLING'S CODE OF SIGNALS.

rl	A	rrrl	K	llr	U
rrr	B	lrrr	L	lll	V
rll	C	lrl	M	rlrl	W
rri	D	lr	N	lrir	X
r	E	rir	O	rllr	Y
rrrr	F	llrr	P	rlrr	Z
llll	G	lllr	Q	rllr	&
rlll	H	lrr	R	lrrl	go on
rr	I	ll	S	lrll	stop
rlll	J	l	T	llrl	finish

rlrlr	1	lrllr	6
rllrr	2	rlllr	7
rlllr	3	rlrr	8
lrrrl	4	llrll	9
lrll	5	llrl	0

## GAUSS AND WEBER'S ELECTRIC TELEGRAPH.

This telegraph seems, by the best authorities, to have been invented in 1833, by Counsellor Gauss and Professor Weber, at Gottingen.

The deflection of the magnetic bar, by means of the multiplier, through the agency of the galvanic fluid, excited by the magneto-electric machine, is the basis of their plan.

Fig. 2 represents a side view of the apparatus, used at the receiving station; *a a* is a side view of the multiplier, composed of 30,000 feet of wire (almost five and a half miles), upon a table *B*; *ns* is the magnetic bar, weighing thirty pounds, from which rises a vertical stem, *o*, upon which is a rod at right angles, supporting a mirror *H*, on one end, and at the other a metallic ball *l*, as a counteracting weight to that of the mirror. The magnetic bar is suspended by a small wire, fastened to the vertical stem, and at the top is wound round the spiral of the screw *i*, which turns in the standard *h'* and *h*, upon the platform *A*, and which is secured to the ceiling. In the standards *h'*, there is cut a female screw, of the same gradation as that upon which the wire is wound. By this means, the magnetic bar may be raised or let down, by turning the screw, without taking the bar from its central position in the multiplier; *g* is a screw for fastening the spiral shaft, when properly adjusted. *r* and *n* are the two ends of the wire of the multiplier. *c* is a stand for supporting the spy-glass *D*, and also the case *E*, into which slides the scale *F*. The mirror *H* is at right angles with

the magnetic bar, and presents its face to the spy-glass *D*, as also to the scale at *E*. It is so adjusted, that the reflection of the scale at *E* from the mirror, may be distinctly seen from the spy-glass. If the magnetic bar turns either to the right or left, the mirror must move with it, and if a person is observing it through the spy-glass, the scale will appear to move at the same time, thereby presenting to the eye of the observer another part of the scale than that seen when the bar is not deflected. The figures on the scale will show in what direction the bar has

Fig. 2.

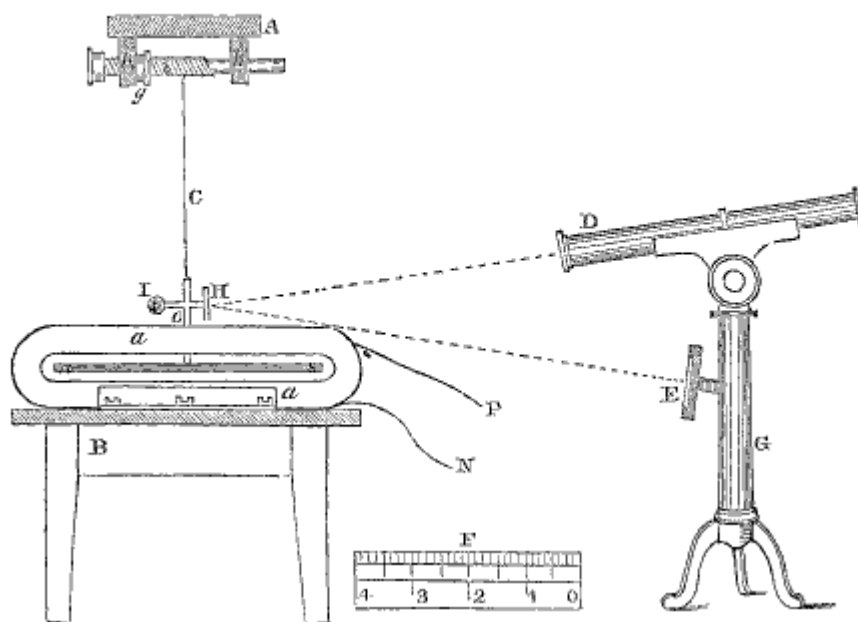

turned, and thus render it distinct to the observer, the only apparent object of the mirror, spy-glass, and scale.

For the purpose of generating the galvanic fluid, they use the magneto-electric machine. There is also required for the purpose of making the desired deflections of the magnetic bar, a communicator or pole-changer. Fig. 2 represents that portion of the apparatus at the *receiving* station. The magneto-electric machine, and the pole-changer, properly connected, are the instruments of the *transmitting* station. Two wires, or one wire and the ground, form the circuit between these two stations. The machine is put in operation by turning the crank, and the person sending the intelligence is stationed at the com-

mutator, and directs the current through the extended wires to the multiplier of the receiving station, so as to deflect the bar to the right or left, in any succession he may choose, or suspend its action for any length of time.

But in the apparatus for observation, the observer looks into the spy-glass, and writes up the kind and results of the variations of the magnetic needle. In order to have a control of the recorder, let there be a good number of spy-glasses directed toward the same mirror, in which observers may watch independently of each other. Suppose that five variations of the magnetic needle signifies a letter, L denotes a variation to the left, and R to the right. Then might r r r r r denote A, r r r l l denote B, r r l r l c, r l l r r denote D, and so on. In the whole; we obtain by the different arrangements of the five, which are made with the two letters R and L, thirty-two different telegraphic signs, which may answer for letters and numbers, and of which we can select those where the most changes are introduced between r and l, as the most common letters, in order, in the best possible manner, to notice the constant variations of the magnetic needle.

The following would be the alphabetical and numerical signs, as arranged from the above directions:

A	r r r r r	I or Y	l l r l l	R	r r r l l
B	r r r r l	K	l r r r l	S or Z	r r l r l
C	r r r l r	L	r l r r r	T	l l r l r
D	r r l r r	M	r r l l l	U	r l l l r
E	r l r l r	N	l l l l l	V	l r r l l
F	l r r r r	O	l r l l l	W	l l l l r
G or J	l r l r r	P	l r l r l		
H	r l r r l	Q	l l r r r	.....	
1	r l l l l	:	6	r l l r r	
2	r r l l r	:	7	l l l r l	
3	r l r l l	:	8	l l r r l	
4	r l l r l	:	9	l r r l r	
5	l l l r r	:	0	l r l l r	

A model to illustrate the nature and powers of this machine was exhibited at the Society of Arts in Edinburgh, Scotland, November, 1837. The model consists of a wooden chest, about five feet long, three feet wide, three feet deep at the one end, and one foot at the other. The width and depth in this model

are those which would probably be found suitable in a working machine; but it will be understood that the length in the machine may be a hundred or a thousand miles, and is limited to five feet in the model, merely for convenience. Thirty copper wires extend from end to end of the chest, and are kept apart from each other. At one end (which, for distinction's sake, we shall call the south end) they are fastened to a horizontal line of wooden keys, precisely similar to those of a pianoforte; at the other, or north end, they terminate close to thirty small apertures, equally distributed in six rows of five each, over a screen of three feet square, which forms the end of the chest. Under these apertures on the outside, are painted, in black paint, upon a white ground, the twenty-six letters of the alphabet, with the necessary points, the colon, semicolon, and full point, to denote the termination of a word. The letters occupy spaces about an inch square. The wooden keys, at the other end, have also the letters of the alphabet,

Fig. 3.

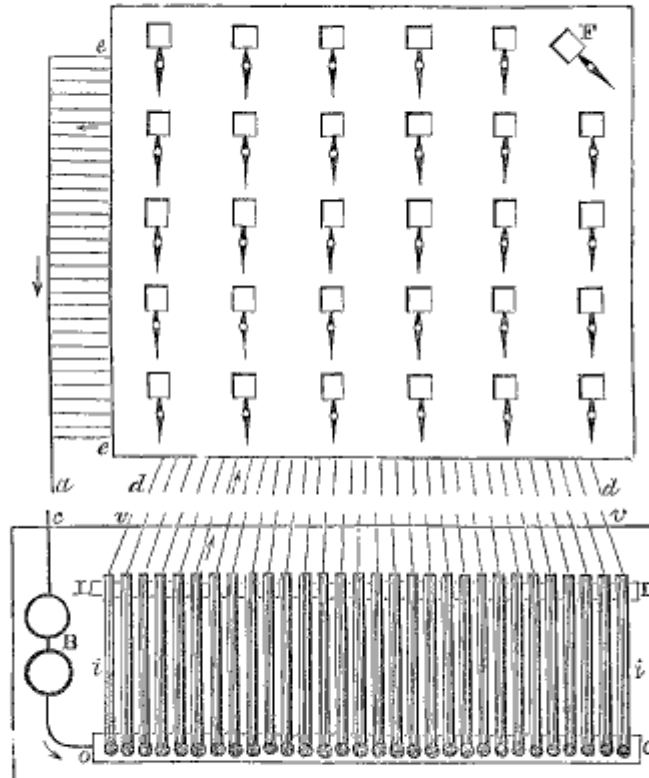

painted on them in the usual order. The wires serve merely for communication, and we shall now describe the apparatus by which they work.

This consists, at the south end, of a pair of plates, zinc and copper, forming a galvanic trough, placed under the keys; and at the north end, of thirty steel magnets, about four inches long, placed close behind the letters painted on the screen. The magnets move horizontally on axes, and are poised within a flat ring of copper wire, formed of the ends of the communicating wires. On their north ends they carry small square bits of black paper, which project in front of the screen, and serve as opercula, or covers, to conceal the letters. When any wire is put in communication with the trough at the south end, the galvanic influence is instantly transmitted to the north end; and in accordance with the well-known law, discovered by Ersted, the magnet at the end of that wire instantly turns round to the right or left, bearing with it the operculum of black paper, and unveiling a letter. When the key, *A*, for instance, is pressed down with the finger at the south end, the wire attached to it is immediately put in communication with the trough; and at the same instant, letter *A*, at the north end is unveiled, by the magnet turning to the right, and withdrawing the operculum. When the finger is removed from the key, it springs back to its place; the communication with the trough ceases; the magnet resumes its position, and the letter is again covered. Thus by pressing down with the finger, in succession, the keys corresponding to any word or name, we have the letters forming that word, or name, exhibited at the other end; the name *VICTORIA*, for instance, which was the maiden effort of the telegraph, on the exhibition before the Society of Arts, above referred to.

The above description is all that I have been able to obtain in relation to this plan of an electric telegraph; and here introduce, fig. 3, to illustrate it. The thirty needles are represented on the screen, each carrying a shade, which conceals the letter when the needle is vertical. The needle belonging to the letter *r*, is, however, deflected, and the letter is exposed. The screen is supposed to be at the *receiving* station. To the left hand of the screen, thirty wires, *e e*, are seen joined to one, *a*; the other thirty wires, *d d*, are seen below the screen.